

FEINIX

TORRES ELEVADORAS
LIFTING TOWERS



INGENIERIA DE CALIDAD

QUALITY ENGINEERING

A stylized world map in shades of gray serves as the background. Overlaid on the map are four large, curved arrows in a light blue-to-white gradient. The arrows form a circular path around the central logo. The logo itself consists of the letters 'FEI VIX' in a bold, green, 3D-style font with a blue outline. The 'V' is notably larger and more prominent than the other letters.

FEI VIX

EN EL MUNDO

IN THE WORLD



Los pilares de nuestra identidad son garantizar productos de alta calidad, proporcionando un servicio serio, integral, eficaz y puntual.

Para llevar a cabo este compromiso, contamos con un equipo humano, con preparación especializada y con mas de 15 años de experiencia.

FENIX como fabricante garantiza:

- Calidad.
- Servicio de asistencia.
- Garantía directa del fabricante.

La calidad de FENIX es reconocida a nivel nacional e internacional.

En FENIX estamos especializados en desarrollar proyectos a medida.

Nuestras estructuras son compatibles a nivel europeo tanto en medias como en ensamblaje.

Todos nuestros productos están fabricados en nuestras instalaciones (España) y han sido certificados con las normativas vigentes [C E 89/392 EWG] [BGV C1, BGG 912].

The pillars of our identity are to guarantee high quality products, delivering a serious service, comprehensive, efficient and precise.

To carry out this commitment, we count with a specialized team with more than 15 years experience.

FENIX like manufacturer guarantees:

- Quality.*
- Technical assistance service.*
- Direct guarantee Manufacturer's.*

The quality of FENIX is recognized nationally and internationally.

In FENIX we are specialized in developing customized projects.

Our structures are compatible to European level so much in measurements as in assembly.

All of our products are made at our facilities (Spain) and have been certified by force regulations [C E 89/392 EWG] [BGV C1, BGG 912].



NEW



TORRES ELEVADORAS

LIFTING TOWERS



XINIX
AT-06
CE



ELV-100/31



Ficha técnica / Technical specifications

Altura máxima / Maximum height	3,20/3,80 m
Carga máxima / Maximum load	100 kg
Altura plegada / Folded height	1,35 m
Área de trabajo / Working area	1,5 x 1,5 m
Peso / Weight	24 kg
Cabestrante / Winch	450 kg



NEW

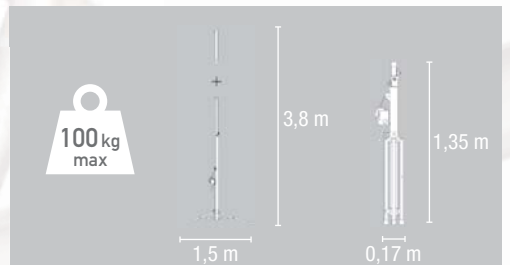

ELV-100/5

Ficha técnica / Technical specifications

Altura máxima / Maximum height	5,00 m
Carga máxima / Maximum load	100 kg
Altura plegada / Folded height	2,05 m
Área de trabajo / Working area	1,59 x 1,59 m
Peso / Weight	37 kg
Cabestrante / Winch	450 kg

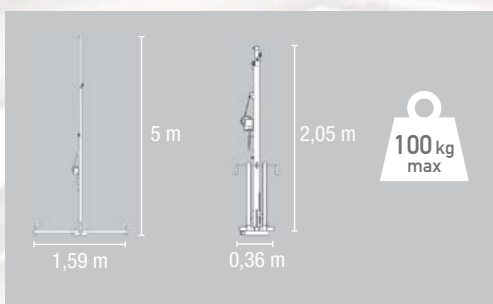

ELV-125/5



NEW



Ficha técnica / Technical specifications

Altura máxima / Maximum height	5,30 m
Carga máxima / Maximum load	125 kg
Altura plegada / Folded height	1,75 m
Área de trabajo / Working area	2 x 2 m
Peso / Weight	60 kg
Cabestrante / Winch	450 kg

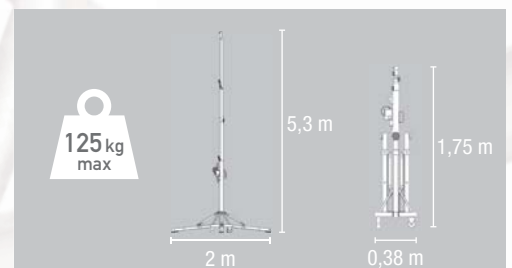

ELV-230/5

Ficha técnica / Technical specifications

Altura máxima / Maximum height	5,30 m
Carga máxima / Maximum load	230 kg
Altura plegada / Folded height	1,82 m
Área de trabajo / Working area	2,1 x 2,1 m
Peso / Weight	90 kg
Cabestrante / Winch	500 kg

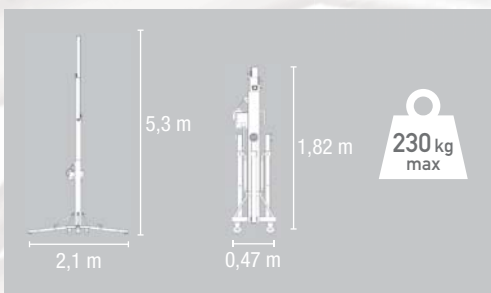

ELV-200/6

Ficha técnica / Technical specifications

Altura máxima / Maximum height	6,40 m
Carga máxima / Maximum load	200 kg
Altura plegada / Folded height	1,92 m
Área de trabajo / Working area	2,1 x 2,1 m
Peso / Weight	97 kg
Cabestrante / Winch	500 kg

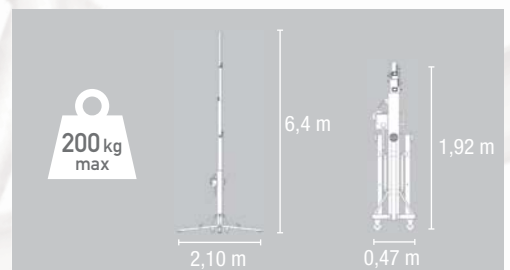

AT-03

Ficha técnica / Technical specifications	
Altura máxima / Maximum height	3,90 m
Carga máxima / Maximum load	180 kg
Altura plegada / Folded height	1,60 m
Área de trabajo / Working area	1,93 x 1 m
Peso / Weight	89 kg
Cabestrante / Winch	900 kg



AT-04

Ficha técnica / Technical specifications	
Altura máxima / Maximum height	5,10 m
Carga máxima / Maximum load	150 kg
Altura plegada / Folded height	1,60 m
Área de trabajo / Working area	1,93 x 1 m
Peso / Weight	99 kg
Cabestrante / Winch	900 kg



Torre Industrial Industrial Tower

AT-05B

NEW



AT-05

Ficha técnica / Technical specifications

Altura máxima / Maximum height	5,40 m
Carga máxima / Maximum load	250 kg
Altura plegada / Folded height	1,76 m
Área de trabajo / Working area	1,62x1,64 m
Peso / Weight	98 kg
Cabestrante / Winch	900 kg

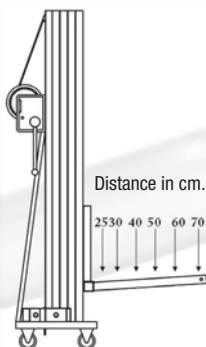

Distancia* Distance*	Carga Máxima Max. Load
25 cm.	250 Kg.
30 cm.	210 Kg.
40 cm.	160 Kg.
50 cm.	125 Kg.
60 cm.	110 Kg.
70 cm.	90 Kg.

* Distancia al centro de la carga a la torre
* Distance from the center of the load to the tower

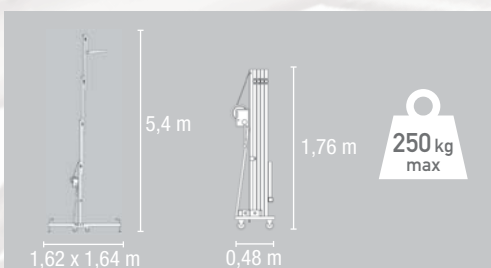

AT-06



NEW

NEW



AT-06B

Ficha técnica / Technical specifications

Altura máxima / <i>Maximum height</i>	6,50 m
Carga máxima / <i>Maximum load</i>	250 kg
Altura plegada / <i>Folded height</i>	1,99 m
Área de trabajo / <i>Working area</i>	1,62 x 1,64 m
Peso / <i>Weight</i>	102 kg
Cabestrante / <i>Winch</i>	900 kg

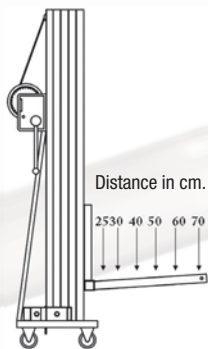

Distancia* <i>Distance*</i>	Carga Máxima <i>Max. Load</i>
25 cm.	250 Kg.
30 cm.	210 Kg.
40 cm.	160 Kg.
50 cm.	125 Kg.
60 cm.	110 Kg.
70 cm.	90 Kg.

* Distancia al centro de la carga a la torre
* Distance from the center of the load to the tower

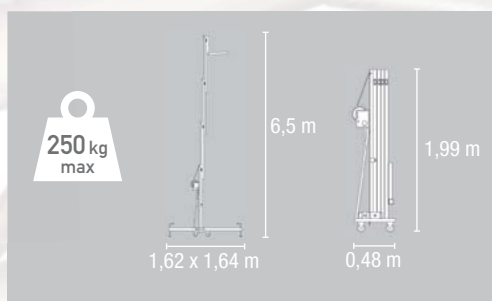

HERCULES 6,5

Ficha técnica / Technical specifications

Altura máxima / Maximum height	6,50 m
Carga máxima / Maximum load	350 kg
Altura plegada / Folded height	1,98 m
Área de trabajo / Working area	2,49 x 2,19 m
Peso / Weight	189 kg
Cabestrante / Winch	1100 kg

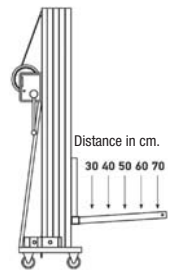

Distancia* Distance*	Carga Máxima Max. Load
30 cm.	350 Kg.
40 cm.	320 Kg.
50 cm.	295 Kg.
60 cm.	280 Kg.
70 cm.	185 Kg.

* Distancia al centro de la carga a la torre
* Distance from the center of the load to the tower



HERCULES 8

Ficha técnica / Technical specifications

Altura máxima / Maximum height	8,00 m
Carga máxima / Maximum load	300 kg
Altura plegada / Folded height	1,98 m
Área de trabajo / Working area	2,49 x 2,19 m
Peso / Weight	208 kg
Cabestrante / Winch	1100 kg

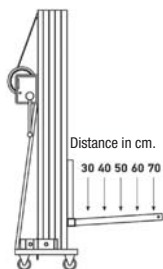

Distancia* Distance*	Carga Máxima Max. Load
30 cm.	300 Kg.
40 cm.	260 Kg.
50 cm.	205 Kg.
60 cm.	185 Kg.
70 cm.	164 Kg.

* Distancia al centro de la carga a la torre
* Distance from the center of the load to the tower

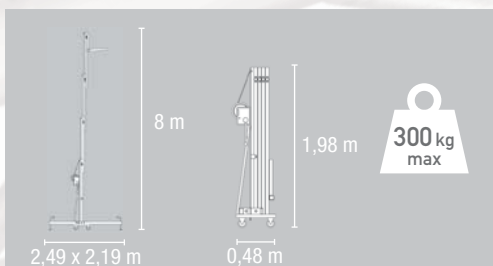

Accesorios Accessories



AC-501



AC-502



AC-504



AC-507



AC-508



AC-533



AC-534

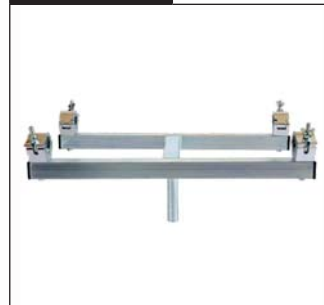

AC-535



AC-564



AC-565



AC-568

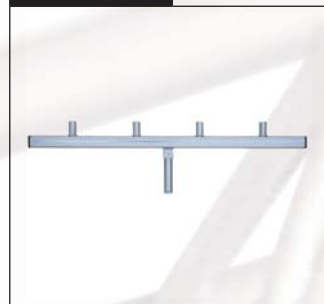

AC-569



AC-570



AC-582



AC-583



AC-584



AC-585



CONDICIONES GENERALES DE VENTA

1. PEDIDOS

- Deberán ser efectuados por escrito (mediante fax ó e-mail), indicando claramente los modelos, de acuerdo con nuestras referencias mostradas en el catálogo.
- Los pedidos deberán estar sellados y firmados por el cliente o persona autorizada. En cualquier caso, la recepción de la mercancía por el cliente se considerará como confirmación y aceptación del pedido.
- No existe pedido mínimo.
- FENIX se reserva el derecho a modificar el diseño o las características de los productos sin previo aviso, no haciéndose responsable de los posibles errores tipográficos que pudieran aparecer en este catálogo.

2. FORMA DE PAGO

- Los pagos deben ser efectuados libre de cargos, al contado, por anticipado, mediante ingreso en efectivo o transferencia bancaria. Nota: Enviar por fax/e-mail justificante del pago realizado. No se aceptan talones. Los gastos ocasionados por la forma de pago escogida por el cliente correrán a cargo del mismo.
- FENIX se reserva la propiedad y titularidad de los productos suministrados hasta que el cliente efectúe el pago íntegro de los mismos.

3. ENVÍOS-PORTES

- La mercancía viaja por cuenta y riesgo del comprador.
- En caso de envíos a portes debidos, éste se realizará por la agencia que el comprador solicite; en caso de envíos a portes pagados FENIX se reserva el derecho de enviarla por la agencia que considere oportuna.
- Toda reclamación por robo y daños en el transporte o demoras en la entrega, deberá hacerse por el destinatario ante la agencia de transportes dentro de las 24 horas siguientes a la entrega de la mercancía. Nota: Igualmente deberán informar a FENIX de la reclamación realizada a la agencia.
- Transcurridos 3 días desde la fecha de recepción de la mercancía por el cliente, FENIX no admitirá ninguna reclamación referente a cantidades, artículos incorrectos, falta de accesorios, etc.

4. DEVOLUCIÓN DE MERCANCÍAS

- No será admitida ninguna devolución de mercancía sin nuestra autorización expresa por escrito.
- Todas las devoluciones deberán ser efectuadas a portes pagados (debidamente embalado para evitar su deterioro).
- El artículo devuelto será abonado con una depreciación del 5 al 15%, en concepto de manipulación, revisión y gestiones administrativas.
- Si en algún caso excepcional acordamos admitir la devolución de algún artículo, éste deberá ser actual, estar en perfectas condiciones y con su embalaje original, manuales y accesorios.

5. GARANTÍA

- Todos nuestros artículos están garantizados contra cualquier defecto de fabricación, por un periodo de 24 meses fecha factura.
- La garantía cubre únicamente la reposición de las partes defectuosas y la mano de obra.
- FENIX no se hará cargo, en ningún caso, de los daños de cualquier naturaleza que pudieran derivarse de una inadecuada utilización o del desgaste normal del producto; Así como aquellos productos que hayan sufrido modificaciones por parte del cliente sin el consentimiento expreso de FENIX.
- Los portes serán siempre a cargo del comprador. Los envíos para reparación en garantía deben ser efectuados a portes pagados y deberán incluir una nota detallada con las anomalías o averías observadas. Todo paquete recibido a portes debidos será rechazado en recepción.
- El servicio técnico tiene establecido un cargo mínimo por reparación y presupuesto, que confirmaremos en cada caso.

6. JURISDICCIÓN

Comprador y vendedor quedan sometidos a la jurisdicción de los Juzgados y Tribunales de Valencia (España).

GENERAL SALES CONDITIONS

1. ORDERS

- Any order implies the acceptance of our sale conditions. All orders shall be made in writing (by fax or e-mail).
- Orders will have to be signed and stamped by the buyer. Acceptance of delivery of Goods shall be deemed conclusive evidence of the Buyers acceptance of these Conditions.
- There is not a minimum Purchase.
- FENIX reserves all rights to make changes as far as construction, weight and dimension without further notice, not being made responsible for any press mistakes that may appear in this catalogue.

2. PAYMENTS

- Customer order can only be accepted against advance payment by bank transfer free of any charge to our account. The expenses generated by a payment condition selected from the BUYER are at his charge. Note: For other way of payment we can charge a general administration fee.
- All goods will remain the property of FENIX until the price of such goods has been paid in full.
- FENIX may at any time suspend the provision of the goods if the buyer is late in making any payment due to FENIX.

3. DELIVERY

- The buyer is responsible for the freight and risks of the merchandise.
- The method of dispatch may be selected by the customer. Without any shipping instructions from the customer, we reserve us the right to arrange the dispatch by any forwarder/courier of our choice.
- The Buyer shall inspect the Goods immediately upon receipt. Any complaints regarding damage, delays or loss must be forwarded to the carrier, as well to FENIX, in written form within 24h from the receipt of the goods. Complaints of suspected bad packing must be forwarded to FENIX on the date of receipt.
- FENIX will not accept any reclamation regarding quantity, missing accessories or incorrect articles after 3 days since the customer received the goods.

4. RETURN OF GOODS

- No goods will be admitted in return without a written authorization from FENIX.
- The freight for returning the goods will be paid by the customer, who will make sure the goods are returned with a reinforced packing so that they arrive in perfect conditions.
- If FENIX were to, exceptionally, accept any article in return, it would have to be in perfect conditions, be returned in its original packing and it has to be a currently catalogued product.
- The returned goods will be refunded with a depreciation of 5 to 15% due to the extra handling, examination and paperwork.

5. WARRANTY

- FENIX warrants that goods shall be free from defects in material and workmanship for a period of 24 months from the date of Shipment unless otherwise specified.
- This guarantee exclusively covers the replacement of defective parts and working hours.
- This warranty does not extend to any of the product: which has been:
 - Subjected to misuse, neglect, accident or abuse.
 - Improperly repaired, or altered or modified in any way.
 - Incorrect operated; used in violation of instructions furnished by FENIX.
 - For the normal wear of the product.
- Defective goods must be returned to FENIX carriage paid and will have to include a written specification of the anomalies and damages observed.
- In case of replacements of parts manufactured by third parties, the guarantee period will be decided by the manufacturer of each part.
- In case of products that have been manufactured by FENIX according to buyer's specifications, drawings or models, FENIX cannot be responsible for the technical quality but its precise execution. In any case, these products are not guaranteed.
- The Technical Service at FENIX has a minimum charge established, as per estimation and repairing, that will be confirmed in each case. FENIX is not liable for personal injury or material damage resulting from negligence, incorrect use, adaptation or maintenance of the goods.

6. APPLICABLE LAW, JURISDICTION

These terms and conditions shall be governed by and construed in accordance with Spanish law. Disputes arising in connection with these terms and conditions shall be subject to the exclusive jurisdiction of the Spanish courts.



FENIX

www.fenixlt.es
info@fenixlt.es
export@fenixlt.es

ROLLSPEED, S.L.
Camino Alquerieta, 10 • Pol. Ind. Massanassa
46470 • Massanassa (Valencia), Spain
Tel.: +34 96 125 08 55 • Fax: +34 96 125 13 05



UNIÓN EUROPEA
Fondo Europeo
de Desarrollo Regional
Una manera de hacer Europa